

For household use

ELECTRIC RICE COOKER Instruction Manual

With cooking menu

Model

RC-18DR1NMY
RC-10DH1NMY
RC-18DH1NMY

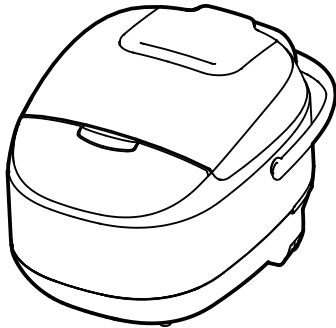

Thank you for purchasing Toshiba rice cooker.

- Please read the instruction manual and use it correctly for your own safety.

Before using, please read “Safety Cautions” and “Please follow the instructions”. (page 2 – 7)

- After reading, please keep the instruction manual at a place where any person who is going to use this cooker can find and see it.

Contents

Before Use	Safety Cautions	2
	Please observe and follow	7
	Parts Identification	8
Rice Cooking	Basic steps to cook rice	9
	How to cook delicious rice	10
	Rice cooking procedures.....	11
	Standard of cooking amounts and cooking times	11
	Display of cooking times	11
	Setting the timer.....	12
	Clock Adjustment	12
“Keep Warm”	13	
Making proper use	Food preparation methods.....	14
	• How to use “Steam” with steam stand ...	15
	• Cake & Crispy Rice	16
	• Sushi	17
	• Soup & Congee	18
Clean & Care / Special notices	Clean & Care	19
	• How to take out and put in the inner lid, steam vent	19
	• Cleaning by boiling.....	19
	In case of problems	20
	Power failure	22
	Error indication.....	23
	Specifications	23

SAFETY CAUTIONS

Please follow for your own safety

- This is to explain the extent of injuries and damages that may occur if the instructions are not followed.

 **WARNING** Probable causes of "severe injuries" or "death"

 **CAUTION** Probable causes of "bodily harm" or "property damages"









- The explanation are divided into sections according to instruction details.

 "PROHIBITION" cases

 "OBSERVATION" cases

 "CAUTION" cases

 **WARNING** To prevent fires, burns, electric shocks, electricity leakage, short circuits

-  • Warning: Avoid spilling to the connector.
-  • Children should be supervised to ensure that they do not play with the appliance.
-  • The heating element surface is subject to residual heat after use, do not touch.
-  • This appliance is not intended for use by persons (including children) with reduced physical, sensory or mental capabilities, or lack of experience and knowledge, unless they have been given supervision or instruction concerning use of the appliance by a person responsible for their safety. This appliance is for household use only. Do not use outdoors.
-  • Don't place the appliance to the place close to heat-sensitive curtains.
-  • This appliance is intended to be used in house-hold and similar locations such as: Staff kitchen areas in shops, office and other working environments; farm houses; by clients in hotels, motels and other residential type environments; bed and breakfast type environments.
-  • If the supply cord is damaged, it must be replaced by a special cord or assembly available from the manufacturer or its service agent.
-  • Please turn off and unplug the appliance before cleaning, maintenance or relocation and whenever it is not in use.

 **WARNING** Misuse may cause potential injury



Stop using immediately if abnormalities/malfunctions are found.

Unplug immediately and contact the Store from which the product was bought or Toshiba service center for examination and repair.

- The power plug / cord is abnormally hot.
- The cooker has a burnt smell.
- The cooker is partly cracked, loosen, wobbling.
- The inner pot, outer lid, or inner lid is broken or deformed.
- The cooking heater becomes bent.



Do not disassemble, repair, or modify the cooker by yourself.

For any repair, please consult the Store from which the product was bought or Toshiba service center.

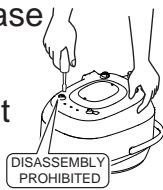

Do not insert any foreign object into the air vent or blank gaps at bottom of the cooker.

Especially metal articles e.g. pins, wire, etc.



Do not immerse the cooker body and the power plug and cord in water or pour water over them.

Do not place them in a place exposed to water.



Do not allow anyone unfamiliar with this cooker handling to use it by themselves. Do not use the cooker where children can reach, particularly keep your eyes on children during cooking or right after cooked.



While cooking, do not open the inner lid or move/carry the rice cooker to other places.

Use the power plug / cord correctly.



- Use a separate socket of 220-240V. Using the cooker with other appliances will result in overheating leading to fire hazards. Do not connect the product to the power source which is not specified in the operation manual.
- If an extension cord is necessary, use it separately.
- Fully insert the plug into the socket.
- Periodically remove dust from the power plug. Accumulation of dust, due to humidity, will cause insulation failure leading to fire hazards. Use dry cloth to wipe dust away.
- Make sure there is no metallic articles or trash (e.g., pin, etc.) left at the pointed end of cooker-plug.



- Do not allow children to flap the plug.
- Hold the power plug head when pulling it out from the outlet. If not, it may catch fire, due to an electric shock, a short circuit, etc. Insert the power plug into the power outlet as far as the base of the power plug.

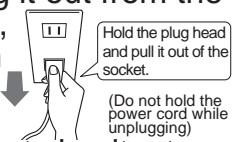

- Always unplug when not in use. If not, due to insulation deterioration, it may cause an electric shock, electricity leakage, fire hazards, etc.

※ Illustration in the instruction manual might be different from the product you purchased.



WARNING

To prevent fires, burns, electric shocks, electric leakage, short circuit, etc.

Use the power plug/cord correctly. (continued)



- Do not use damaged cords/power plugs, etc., or those with loose insertion.
- Do not let steam reach the power plug or other electrical appliances. Especially be careful when using any kitchen storage shelf.
- Do not use any power cords other than the cooker attachments and do not use the cooker attached cords for other appliances.
- Do not place the power plug or cord in the place with high temperature, flooded water, and high humidity or touch it with sharp-edge object.
- If power cord damaged, purchase specified replacement from the producer.



- Handle the power cords with care. Do not pull, tuck, twist, bend them with force in unnatural ways or turn on electricity while they are still coiled. Do not place heavy objects on their tops. Do not modify or deform them in any way.
- Do not insert or pull out the power plug or the cooker-plug with wet hands. Make sure your hands are dry before touching the power plug.



Do not touch the product, cord, or power plug with wet hands. Do not operate the product if the cord or power plug is damaged, or the power plug is inserted improperly.

Use the power plug/cord correctly. (continued)



The steam vent is hot. Keep your face or hands away from it.
Be careful, especially with babies and infants.



Make sure to install the steam vent.



Do not use the cooker for any purposes other than those indicated in the instruction manual.
Because it may cause food or steam contained inside spill or burst out, resulting in burn wounds/injuries.

«Examples of inappropriate cooking ways »

- Putting materials that may block the steam vent, for example, cooking sheets, aluminum foil, lye-removing sheets, food wraps, or thin-layer ingredients such as greens, tomatoes, beans, etc.
- Cooking the food that's easy to spill out e.g., jams, beans, etc.
- Putting ingredients in plastic bags and heating in the cooker.



CAUTION

To prevent electricity leakage, electric shocks, bodily harm, burn wounds, fire hazards, and property damages.

To prevent boiling over or spilling out



- Rice porridge is to be made with lots of water, so we don't use "White Rice" or "Quick Rice" menu. Please make rice porridge by "Congee" menu.



- Do not increase water too much more than the indicated water level scale. The standard is within 2 mm against the indicated water level scale.

To prevent burn wounds / injuries.



- While using or after using, do not touch hot parts including the inner lid, the cooking heater, the inner pot, the steam vent, the heat sink, etc.



- When not in use, do not press the "Cook" key or "CANCEL/KEEP WARM" key. Because the cooking heater, the inner pot, the outer pot, the inner lid will be at high temperature.

- While moving the cooker, do not touch the hook button.
- Do not shake the cooker while holding the handle.
- While cooking, do not set up the handles.
- Do not turn on the cooker, when the pot is empty. Because it may cause overheating, breakdowns, and malfunctions.



- To maintain or repair, do it after unplugging and the cooker has cooled down. There may be hot water still gathering in the steam vent.
- After cooking, beware of steam or hot water dripping from the inner lid, while opening it.
- Before take out the inner pot, press the "CANCEL/KEEP WARM" key. Although the inner pot is taken out during cooking or warming, the power will not be automatically cut off.
- Please use a dry dishcloth, mittens, etc. to take out the hot inner pot.

(continued)

SAFETY CAUTIONS

Please follow for your own safety



CAUTION

To prevent electricity leakage, electric shocks, bodily harm, burn wounds, fire hazards, and property damages.

Do not use the cooker in the following places



- A place where near the naked flame, wet area, or hot and high humidity area.

Also beware for the accessories and attachments.

- An uneven/unstable place or on heat-sensitive carpets, mats, etc. They may cause burn wounds, fire hazards.
- On materials that may block the air vent, for example paper, cloth, carpet, etc.
- A place where the lid cannot be fully opened. It may cause burn injuries and damages.

- The high electromagnetic area.
- A place close to walls, furniture, etc.

When putting the cooker on a kitchen storage shelf, be careful not to let steam be confined.

- Sliding table with insufficient load strength.

The load strength standard is

- 1.0L type : 10 kg and up;
- 1.8L type : 12 kg and up;

For safe use



- Do not use any other things instead of the inner pot which is specifically designed for the cooker.
- Do not bring any flammable object, hazardous object, chemicals, or flammable gas near or in the product.
- Read the instruction manual carefully and thoroughly before using the product.
- Always inspect that the product is in a good operating condition before using by following the recommendation in the instruction manual.
- Remove all packing materials.

Please observe and follow

To prevent breakdowns, malfunctions, etc.

Do not use the cooker in the following places.

They may cause malfunctions, deformation, discoloration, etc.

- A place which is exposed to direct sunlight
- A place where oil, etc., splashes

Do not put any dishcloth on the lid, especially on the steam vent.

Steam may be confined, resulting in malfunctions, deformation, discoloration, etc. of the lid, the steam vent, and operation parts.

Keep the cooker and surroundings clean and ready to use. Dust, bugs, etc. entering inside of function-maintaining parts (such as the air vent, etc.) may cause malfunctions of the cooker.

Do not use the cooker in the following ways to prevent coating inside the inner pot from getting scratched and getting unstuck

- Do not put dishes in the inner pot and use it as a washing-up bowl.
- Do not use a scrubbing brush or dish washer to wash the inner pot.
- Do not use any cleanser, bleaching agent to wash the inner pot. (use neutral detergent for kitchen use.)
- Rice seasoned and cooked with various ingredients cannot be kept warm. (Please wash right after using seasonings.)
- Do not use vinegar.
- Do not scrub with a scoop or strike with a sieve.
- Do not use a metal ladle or a whisk.

Wipe away water droplets or any foreign substances.

If using while foreign substances are left, stuck to the cooking heater, the temperature sensor, the outer part of inner pot, the packing of inner lid, etc., rice will not be well cooked, resulting in malfunctions.

Do not use the inner pot with a gas range, IH cooking appliances, microwave ovens, etc.

They may cause deformation, discoloration, malfunctions, etc.

Stop using if the cooker become loose, cracked, fell down.

Please contact the store from which the product was bought or Toshiba service center for examination and repair.

Parts Identification

- When using for the first time, please wash the inner pot, inner lid, steam vent, other accessories and attachments
- At first use, there might be an odor from plastic, etc. This odor will disappear after using

Body

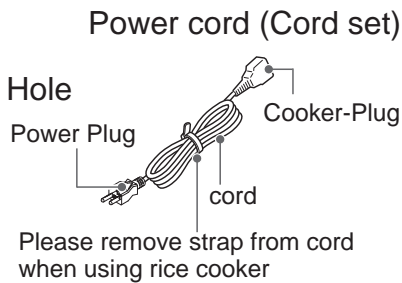
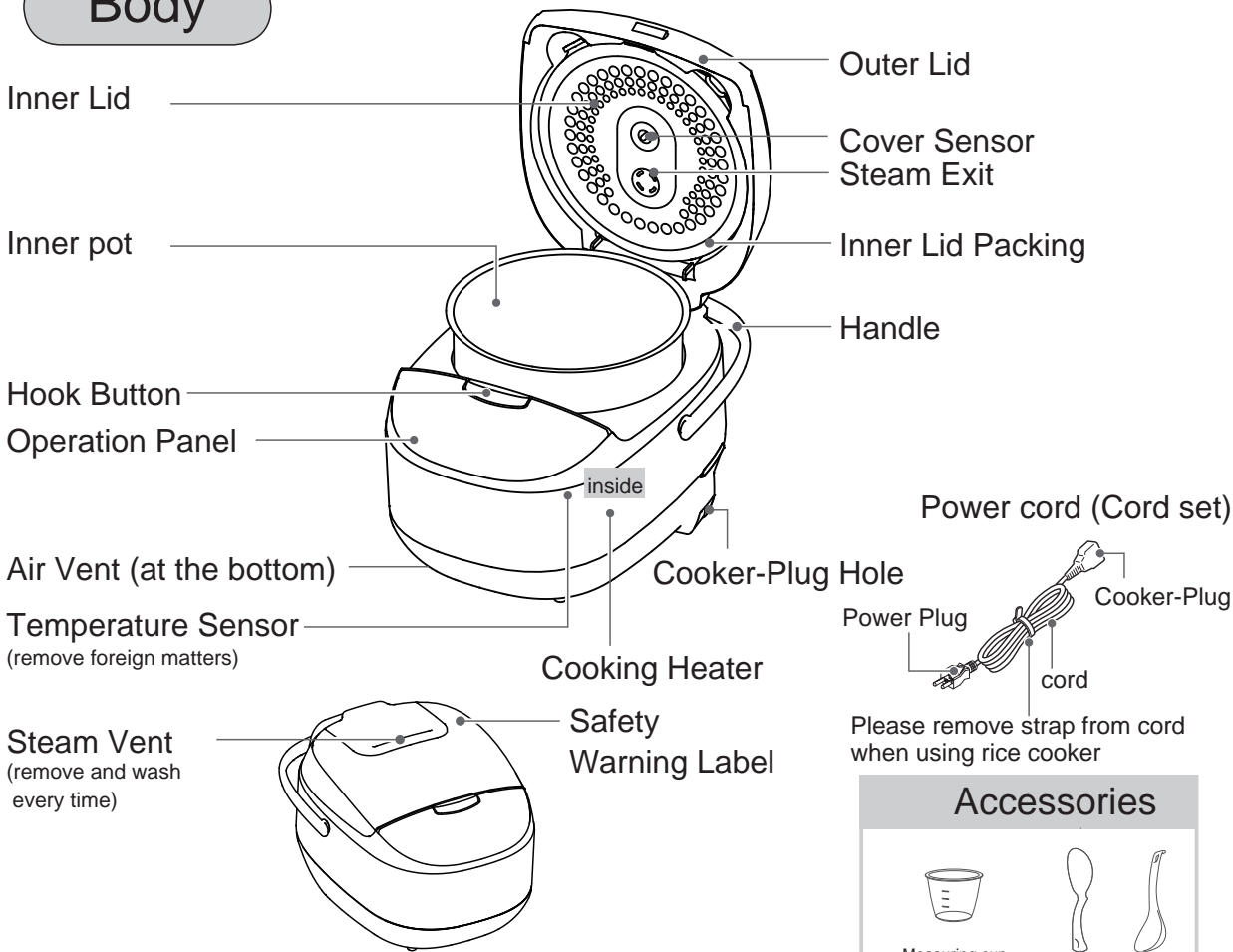

Accessories

Measuring cup (approximately 180 ml.)

Scoop

Spoon

For Model: RC-10DH1NMY

For Model: RC-18DR1NMY

Operation Panel

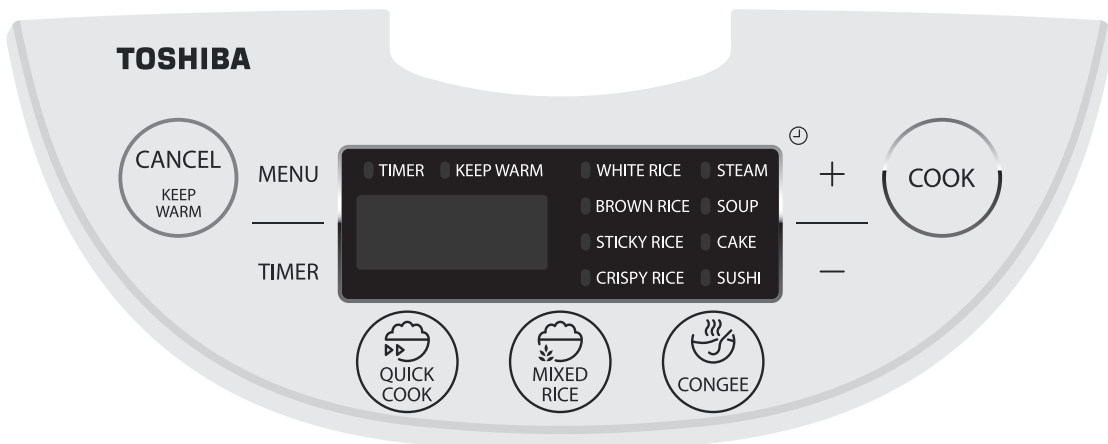

Basic Steps to Cook Rice

Preparation

1 Measure rice with the measuring cup provided.

A level cup = 180ml

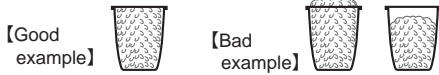

- It might differ from other food measuring cups (200ml) or other rice measuring vessels.

2 Wash rice. Quickly rinse the rice until the water runs clear.



- ① Fill plenty of water, swirl the rice around quickly and gently (with one hand), then pour out the water immediately.
 - ② Polish the grains of rice and rinse several times, until the water runs clear.
- In case of washing rice in the inner pot, please do not use any whisk.

3 Adjust the water level. Select the water level scale based on the size and number of the measuring cup.

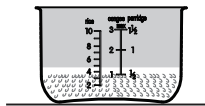

Level off the rice, on a flat place.

- please adjust the water level according to your taste.
- ❗ Standard: adjust within 2mm against the indicated scale

4 Wipe off water droplets, foreign substances, and set the inner pot, then close the lid.



If there are water droplets or foreign substances left or stuck to the following parts, please wipe off.

- Water droplets or foreign substances left may cause steam leakage, cause the lid to fail to close completely, and cause the rice not to cook well,

Levelly place the inner pot on the bottommost part inside the cooker (without inclination to either side).

Turn the inner pot 2-3 times in the direction as shown by the arrows, to have it closely touch the cooking heater.

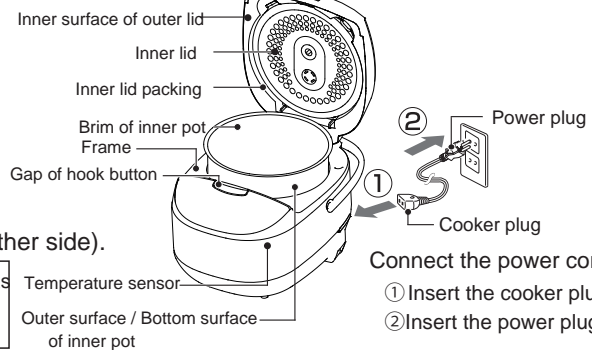

Connect the power cord:

- ① Insert the cooker plug.
- ② Insert the power plug.

5 Select the cooking menu, confirm, and start cooking.



Press the "Cook" key.

- There's no need to soak the rice.
- Please do not forget to close the lid and attach the steam vent.

If the buzzer sounds, it indicates that the rice has cooked. After using, press the "CANCEL" key and unplug from power outlet. "KEEP WARM" lamp turns on.

- ❗ Please press the "CANCEL" key to cut off power before removing the inner pot.
- ※ During keeping the rice warm, although removing the inner pot, the cooker will not turn off automatically.

- In the case of "cooking immediately after keeping warm" or "continuously cooking" please wait until the temperature of the inner lid, the temperature inside the cooker, etc., have cooled down to the normal human body temperature.

How to cook delicious rice



Measure rice accurately (level off the top).



Do not shake the measuring cup

If shaking, the amount of rice will increase more than enough.

Measuring cup provided with the cooker

Do not wash rice with hot water.

Do not wash rice for a long time.

Washing with hot water or washing slowly may cause a bad odor of rice bran.

Gently wash, to avoid smashing the rice grains.

Lightly rub the rice grains one another. (Cracked or broken rice tends to get mushy and sticky when cooked.)

Adjust water level according to preference.

If preferring harder rice	lower the water level below the indicated scale
If preferring softer rice	raise the water level above the indicated scale

Freshly-harvested rice	slightly below the indicated scale
Whole rice	according to the indicated scale
Old Rice	
Rice during rainy season to summer	slightly over the indicated scale
Wheat	

The condition and quality of each kind of rice is different, depending on brands, places of origin, storage conditions. Therefore, please adjust according to your preference.

When cooking is finished, loosen the cooked rice entirely with a scoop.

Please loosen the cooked rice by holding the inner pot with a dry cloth or mittens to prevent it from clumping or sticking together.

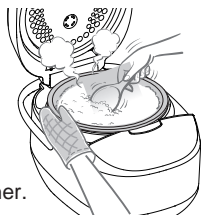

“Keep warm” operation should end in a short period of time.

In the case of “rice seasoned and cooked with various ingredients”, small amount of rice, or keeping warm for extended periods, it is advised to wrap in plastic wraps and keep in the freezer.

About Rice

- Buy a proper amount of new rice of which the rice-polishing date indicates that it can be completely consumed within 2 weeks - 1 month.
- Prevent oxidation by keeping rice in a tightly closed container and store it in a dark, cool place.

After washing, do not leave the rice in a colander.

Avoid leaving the rice in a colander.



The rice grains may get cracked resulting in becoming mushy and sticky when cooked.

Unsuitable kinds of water for rice cooking

Hard mineral water



Ionized water over pH9

(A cause of hard and dry rice)

(A cause of mushy and sticky rice)

Rice cooking water should be 30°C or lower.

It is recommend to use cold water for pre-programmed cooking in summer.

In summer, use cold water



(Too-high water temperature will result in undelicious cooked rice and unpleasant odor.)

After using, immediately clean and care.

Wash and keep the inner lid, inner pot, steam vent clean all the time.

After washing, wipe off water droplets with a clean cloth.

(Leaving the cooker dirty will cause bad smells.)

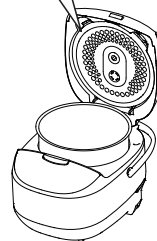

After stop “Keep Warm” operation, do not leave rice in the pot (or it will cause unpleasant odors).

Rice Cooking Procedures

Operation Method

Operation	<p>1 Select the cooking menu with Menu</p> <p>Adjust to the cooking menu</p>	<ul style="list-style-type: none"> ● Every time we press the “Menu” key, “I” mark will move and the selection will consequently change.
	<p>2 Cooking starts, after pressing COOK</p>	<ul style="list-style-type: none"> ● Press the “COOK” key, the lamp of the corresponding menu will be from flashing to being on all the time.
Rice Cooked	<p>When rice is cooked, the buzzer sounds to show cooking is finished.</p> <p>TIPS Immediately loosen cooked rice</p> <p>Keeping warm automatically</p> <ul style="list-style-type: none"> ● Please keep the rice warm for not longer than 12 hours for DR series, 6 hours for DH series. 	<ul style="list-style-type: none"> ● [“KEEP WARM” lamp] turns on. Showing the elapsed time for keeping rice warm in units of one minute.
<p>After using Press “CANCEL” key and pull the power plug from the outlet.</p>		

Select the “Water level scale” and the “Rice Cooking menu” that match the type of rice to be cooked.

Cooking menu	Type of rice to be cooked	Water level scale	cooking amounts of rice unit : cup		Standard times for cooking unit : minute	
			1.0 L type	1.8 L type	1.0 L type	1.8 L type
QUICK COOK	White rice	White rice	1-5.5	2-10	30~45 min	30~45 min
MIXED RICE	Mixed rice	Mixed rice	1-4	2-6	60~80 min	60~80 min
CONGEE	White rice	Congee	0.25-0.5	0.5-1.5	2 Hour	2 Hour
WHITE RICE	White rice	White rice	1-5.5	2-10	40~50 min	40~55 min
BROWN RICE	Brown rice	Brown rice	1-4	2-6	60~80 min	60~80 min
STICKY RICE	Sticky rice	White rice	1-4	2-6	35~55 min	45~65 min
CRISPY RICE	White rice	White rice	1-4	2-6	60~70 min	60~70 min
SUSHI	Sushi Rice	White rice	1-5.5	2-10	40~50 min	40~55 min

- Actual cooking time may vary by about 10 minutes, depending on amounts of rice, amounts of water, water temperatures, etc.
- For all cooking menu, don't add water exceed to the “MAX” level scale.

Setting the timer

Cooking at the preset time.

Please do not use pre-programmed settings for germed brown rice, rice mixed with cereals, and rice seasoned and cooked with various ingredients.

Preparation



Put the inner pot in the cooker and close the lid.

Operation

1 With  set the cooking menu, adjusting to make it proper for the kind of rice to be cooked

2 Press 



3 Set the completion time with  



【example : The rice will finish cooking at half past one.】

- The completion time can be set in units of 10 minutes.
- If we keep pushing “+” key or “-” key for a while, the time display will change quickly.

4 Press  Pre-programmed cooking is completed

- Pre-programmed time will be displayed until rice-cooking starts.
- When rice-cooking starts, the “TIMER” lamp will turn off.
- If the “COOK” key is not pressed, it will exit from preset mode to standby mode after 2 minutes.

When desiring to cancel the pre-programed settings or if the operation is incorrect

Press 

Setting the timer

Possible pre-programmed menus

- Please do not use pre-programmed function to each of the following items marked with "X".

white rice	brown rice	sticky rice	crispy rice	steam	soup	cake	sushi
○	○	○	○	○	○	×	○

Pre-programmed Time

- Please do not set preprogrammed times so long over 14 hours (maximum 8 hours in summer). Too long preprogrammed time will cause decay and unpleasant odors.
- If the preprogrammed time is not more than the cooking time of the selected menu, the cooker will start cooking at once.

Notice

- If the cooked rice is quite soft, please reduce the water according to your preference.
- In case of pre-programmed cooking, starchy substances will sink to the bottom and may become light brown.
- In case of low room temperatures, low water temperatures and large amounts of water, rice may cook later by about 10 minutes.

“KEEP WARM” feature

After cooking, the rice will automatically be kept warm.

- “KEEP WARM” temperature can be controlled automatically depending on using conditions, in order to keep our rice warm and delicious.
- Press the “Cancel” key, when desiring to stop “KEEP WARM” operation.
- During keeping rice warm, although the inner pot is removed, power will not be cut off automatically.

- Do not use the “Keep Warm” feature in the following cases: (They are causes of bad odors and decoloration)
 - using for longer than 12 hours for DR series, 6 hours for DH series.
 - using for any rice other than white rice. (e.g. germed brown rice, congee, rice seasoned and cooked with various ingredients, etc.)
 - using while there is a scoop, etc. in the pot.
 - using for cold rice.
- Do not stop "Keep Warm" operation, while the rice is still in the inner pot. (It may cause a bad smell)

If the display blinks during “Keep Warm” operation, please press the “Cancel” key, and take the rice out.

Tips for keeping rice warm

- Gathering rice to central part will help it not to get too hard, too mushy and sticky.
- During keeping rice warm, If worrying that it may get too mushy and sticky, please do not let the rice left at the side of inner pot.

When desiring to keep rice warm after finishing cooking.

Operation

If pressing  it will start to keep the rice warm.

- “Keep Warm” lamp will turn on.

When desiring to stop keeping rice warm

Operation

If pressing 



Before taking out the inner pot, please press the “Cancel” key and unplug to cut off power.







- “KEEP WARM” lamp turns off.
- ※During keeping rice warm, when the inner pot is removed, power will not be cut off automatically.

Food Preparation Methods

⚠ WARNING

Please do not cook or use any ingredients which are not mentioned. Because they may cause steam or ingredients to spill over or scatter, resulting in burn wounds, injuries, damages, etc. Besides, they may be causes of inner-pot corrosion, bad odors, etc.

Basic procedures

Operation	<p>1 Select menu by </p> 	<ul style="list-style-type: none"> • Every time the “MENU” key is pressed,  will move, and the selection will consequently change.
	<p>2 Adjust time by “+” and “-”</p>  <p>【 Ex. Cooking time 3 hours 】</p>	<ul style="list-style-type: none"> • Only the “ STEAM ” and “ SOUP ” can adjust time. • When you choose the “Soup” key, it can be set to the maximum of 4 hours with 10minutes/unit. • When you choose the “Steam” key ,it can be set to the maximum of 60 minutes with 1 minute / unit. • If keep pressing the key, times displayed will change more quickly.
Completion	<p>3 Start cooking by </p> 	<ul style="list-style-type: none"> • Press the “ COOK ” key, the lamp of the corresponding menu will be from flashing to being on all the time.
	<p>When cooking is finished, the buzzer sounds.</p> <ul style="list-style-type: none"> • Please use pot holders to take the inner pot out, because it is very hot. • Do not leave any food in the inner pot for a long time. 	<ul style="list-style-type: none"> • It is easy to smell bad, so please always clean with good care. Please clean by boiling whenever worrying about any bad odor.

Notes

- Don't add water over “MAX” water level.
- “Food preparation” times mentioned in the instruction manual are for reference only. The actual time results may vary depending on ingredients, room temperature, etc.
- Please use plastic or wooden cooking utensils, to prevent the inner pot from getting scratched.
- Make sure the inner pot has been put properly in the cooker. If it does not closely touch the cooking heater, the food may not be well made.

How to use "STEAM" with steam stand

How to pour water

Take the model of RC-10DH1NMY & RC-18DH1NMY as an example:

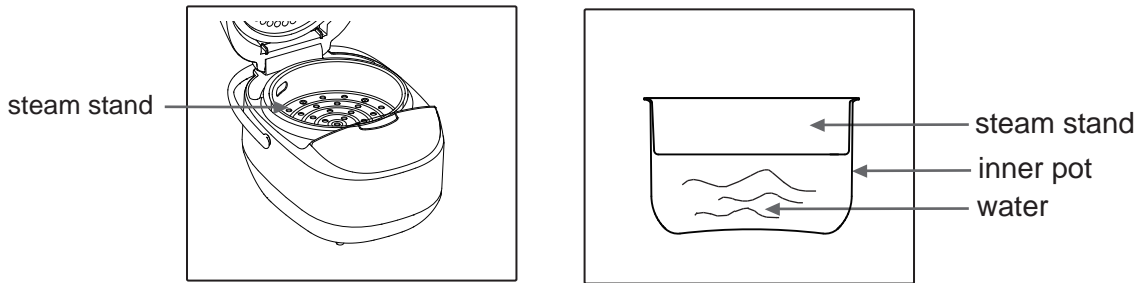

Rice cooker	Water level
1.0L type	Follow "White Rice" wate level 2
1.8L type	

CAKE

- 1 Ingredients preparation:
Small amount: 3 eggs, 100g caster sugar, 120g cake flour (baking powder), 30g butter (not melted).
Large amount: 5 eggs, 180g caster sugar, 200g cake flour (baking powder), 50g butter (not melted).
(Cake tests for Large amount are not carried out for below models: RC-10DH1NMY).
- 2 Put in sugar and eggs, stir with a whisk until it is frothy. Then add cake flour and stir with a wooden spoon. Add melted butter, stir quickly and quickly pour into the electric cooker inner pot for operation before the bubbles disappear.
- 3 Press the "MENU" button and choose "CAKE" function, then press "COOK" button.
The cooking time is around 45 minutes.



CRISPY RICE

- 1 Put rice that is washed clean into the inner pot, and add water to the corresponding water line based on rice amount (3 cups of long grain rice) as well as the appropriate amount of peanut oil.
- 2 Close the lid, press "MENU" button to select "CRISPY RICE" function, and press "COOK" button, and wait patiently for the function to end.

SUSHI

- 1 Ingredients (for 4 people):
China's northeast rice or special rice for sushi: 300 g
Seasoned vinegar (mixed in advance): Vinegar (6 big spoons), sugar (1 big spoon) and salt (1 small spoon)
 - 2 Wash rice quickly until the water is clear, add water to the water level scale 2 for "WHITE RICE", and close the lid.
 - 3 Select the "Sushi" function, and press the "COOK" button, the cooking time is around 50 minutes.
 - 4 Wipe the sushi barrel with a cloth soaked in vinegar water, and pour cooked rice into the barrel.
 - 5 Spread seasoned vinegar on the rice, then mix it with the rice. Fan the rice with a round fan until it renders luster.
- *Do not mix seasoned vinegar with the rice in the inner pot.**



Cooking tips (as follows)

- Mix seasoned vinegar with the rice when it is still hot, so that seasoned vinegar can be fully blended into the rice.
- The reason why we use a sushi barrel is that excess water can be absorbed by it, so that rice will not get sticky.
- Replacing water with chilled kelp water for rice cooking can make rice more delicious.

SOUP

- 1 Prepare soup ingredients (such as chicken, corn, carrots etc.), wash all ingredients and cut into small pieces, then put them into the inner pot, and add water not more than Max water line.
- 2 Close the lid, press the “MENU” button to select the “SOUP”, then press the “COOK” button, and wait for cooking to be completed.

CONGEE

- 1 Prepare rice and water. Place the rinsed rice into the inner pot and choose the appropriate water level according to rice amount.
Note: You may adjust the amount of water according to personal preference.
- 2 Close the lid, and press the “Menu” button to select “Congee”.
- 3 Start cooking Press the “COOK” button to enter the cooking state, and the cooking will be completed in designated time.

NOTE:

- The pre-set time is suggested not for more than 12 hours, otherwise the off-flavor may occur;
- To ensure the best cooking effect, the pre-set operation is not suggested for the “Crispy Rice”.

Clean & Care



Using an unclean cooker will result in bad odors, etc. Therefore, please keep it clean all the time. Always make sure to wipe off the water droplets from the steam vent, inner pot /packing.



CAUTION

Unplug the cooker before cleaning and caring.
(It is a cause of burn wounds)

Please do not use the following materials

(They are causes of deformation, decoloration, corrosion, cracks scratches)

- Dish washers / dish dryers
- Detergents other than neutral detergent for kitchen use
- Benzene, thinner, alcohol, cleanser, bleaching agent
- Scrubbing brushes, melamine sponges which easily cause scratches

The inner lid is made from aluminum. It may be decolorized by detergents used for dish washers.

The inner pot, the inner lid, the steam vent, and scoop should be washed after each use.

The measuring cup should be washed with neutral dishwashing detergent. Adding seasonings in the pot without washing the inner lid after that, will result in rusting

Do not wet the cooker body, cooking heater, temperature sensor.

Wipe off dirt and foreign substances with a well-wrung cloth.

- Do not wash without taking it apart. Do not wet the operation parts and outer lid (cover lid). Do not pour water into the inner side of the cooker body.
- Do not pull the heat sink packing forcefully. (It does not come off)

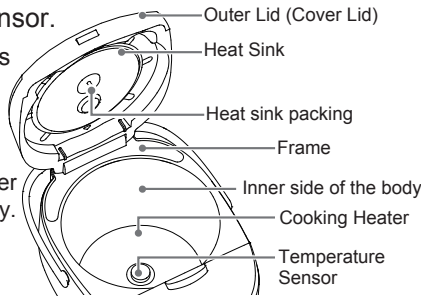

Use cotton buds to remove dirt, foreign substances from the air vent (at bottom of cooker body) and hook button gap.

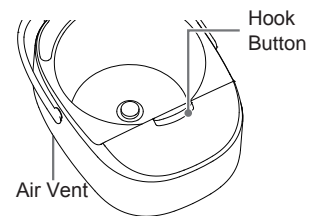

If there are any grains of cooked rice left at the cooking heater/temperature sensor, please rub gently with soft-sandpaper (approximately no. 600), and wipe off with a well-wrung cloth.

Steam Vent

Each time of use

Remove by

pulling up to the top direction



Set the brim

to the hollow part and push down completely

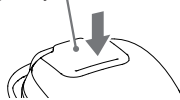

Open

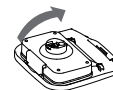

Close



Inner Lid

Each time of use

Remove by

pulling forward

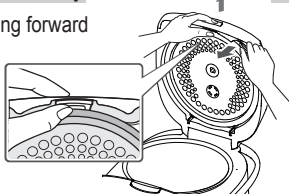

Attach

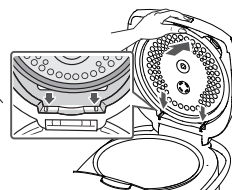

- ① Insert at the direction of the lower two shears.
- ② Press to make it fully attached.

- Without attaching the inner lid, the outer lid (cover-lid) cannot be closed completely (to prevent forgetting to attach the inner lid)

Cleaning by boiling (approximately once a week) Please also do whenever it smells unpleasant.

- 1 Put water in the inner pot (until it reaches the water level scale 2 for White Rice), and close the lid.
- 2 Select (White Rice) with "Menu" key, and press "COOK" key.
- 3 When it becomes "Keep-Warm operation", press "Cancel" key. When the cooker has cooled down, remove the inner lid, inner pot and steam vent, wash and dry them.

- Do not put anything (for example. detergents, etc.) other than water.
- Do not consecutively clean by steam.
- Some smell may not be completely absent.

In Case of Problems

Before making repair requests, please investigate once more. If cannot investigate or take further action by yourself, please make an inquiry to Toshiba service center.

Trouble Cases		Causes / points of investigation
<p>The cooker doesn't power on. The rice does not cook. The cooked rice is tepid although being handled with "Keep-Warm" function. The rice is juicy. Key operation cannot be performed.</p>		<ul style="list-style-type: none"> Is the cooker unplugged or does the plug fall out of the outlet ? If the current time is displayed during the cooking or the "Keep Warm" operation, the cooker is in a power failure state and the plug is disconnected or the circuit breaker shuts down power.
Rice	<p>Soft Mushy, Sticky Clumping together Undelicious</p>	<ul style="list-style-type: none"> Please cook the rice with less water. When the rice has cooked, loosen it immediately and entirely. Please cook new rice with less water. Soaking beforehand will soften the texture of rice cooked with pre-programmed settings. Washing the rice grains forcefully or leaving it in a colander may cause it to get cracked and become mushy, sticky when cooked. Is it cooked with hot water or alkaline ionized water with pH 9 or higher ?
	<p>Hard Dry Undelicious</p>	<ul style="list-style-type: none"> Please cook the rice with more water. Please soak the rice grains before cooking. Was it cooked with mineral water which has high degree of hardness ?
	<p>Getting scorched ※ Getting a little burnt and turning to light brown is not a result of breakdown or failure</p>	<p>Rice gets scorched easily in the following cases:</p> <ul style="list-style-type: none"> When rice has not been washed enough. When soaking time is too long. For wash-free rice (Musenmai), rinsing 1 - 2 times can reduce scorch problems. When there are dirt or foreign substances stuck to the temperature sensor. When adding seasonings to rice cooked with several ingredients. When cooking germed brown rice, etc.
	<p>Undelicious, Not cooked well</p>	<ul style="list-style-type: none"> Do you cook rice while the cooker inner-side, inner-lid, etc. are still hot or warm? Please wait until their temperatures have cooled down to the same level of human body. In case of "Quick Cook" operation, the rice may be rather hard, or rather soft. Are there any foreign substances stuck to the temperature sensor, inner-lid packing, steam vent, etc.? Is the inner pot deformed? Did you forget to attach the inner lid, steam vent, etc.? Was there any power failure? Was the cooker unplugged ?
Rice kept warm	<p>Unpleasant odors ※ In case of having unpleasant odors, please clean by boiling and get it dried before the next use.</p>	<ul style="list-style-type: none"> Please check if "KEEP WARM" function has been used in the following ways: Using for a too long time. Using other programs than white rice. Using for cold rice. Using when a scoop is still put in the pot. Using for 12 hours for DR series, 6 hours for DH series or longer. Is the cooker body / inner lid / steam vent dirty ? Please particularly remove the inner lid / the steam vent to wash and use a clean cloth to wipe off water droplets every time after cooking. Has the rice been washed enough? Is the pre-programmed cooking time is too long? Is the rice left in the pot, with the "Keep Warm" mode off? (Pressing the key by mistake, or disconnecting because of a power failure) Did you leave the rice in the inner pot after turning off the "Keep Warm" operation? Please check the above details and change the "Keep Warm" settings.
	<p>Turning a different color Dry.</p>	<ul style="list-style-type: none"> Is there any foreign substances stuck to the inner lid packing, the brim of inner pot, or the frame of cooker body? Is there any foreign substances stuck to the temperature sensor or the outside of inner pot? Is the steam vent attached properly? Is "Keep Warm" time too long? Has the rice been repeatedly reheated? "Keep Warm" operation with a small amount of rice may cause the rice at the bottom to get hard and dry, so please gather and pile the rice at the central part.

(continued)

Trouble Cases		Causes / Points of investigation
	Mushy, Sticky	<ul style="list-style-type: none"> • Please cook rice with less water, then keep it warm. • After the rice has cooked, loosen it immediately and entirely. • Gather rice at the central part of the pot and sometimes mix together entirely, to prevent it from being left at the inner surface of inner pot.
Rice Cooking • Keeping warm	Steam leakage ※Check after the rice has cooked	<ul style="list-style-type: none"> • Are there any foreign substances stuck to the inner-lid packing, inner-pot brim, or on the cooker frame? • Are there any scratches at the inner-lid packing? Are there any deformation of the inner lid / inner pot? • Is the inner lid attached properly?
	Boiling over Spattering	<ul style="list-style-type: none"> • Are there any problems of small amounts of rice, large amounts of water, insufficient rice washing? • Did you make any mistake of porridge cooking menu ? • Are there any foreign substances stuck to the temperature sensor? • Is it dirty inside the steam vent ? • Are the inner lid, the steam vent attached properly?
	Thin films appear at the inner pot.	<ul style="list-style-type: none"> • Oblate-shaped films are sweet constituents (starch) of rice which have melt and dried. There is no abnormality in this case.
	Water droplets appear at the inner lid, inner pot, etc.	<ul style="list-style-type: none"> • Water droplets may appear at the inner lid, inner pot, etc., in order to prevent drying. There is no abnormality in this case.
	When opening the lid, water drips from the packing, etc.	<ul style="list-style-type: none"> • When opening the lid, there may be some liquid dripping from the frame, etc., depending on lid opening times, room temperature, etc. • Are there any foreign substances stuck to the temperature sensor/the outer side of inner pot ?
Pre-programmed settings	Cooking starts immediately	<ul style="list-style-type: none"> • If pre-programmed times are within the time of the cooking menu, it will start cooking at once.
	Rice does not cook at the pre-programmed time Pre-programmed operation cannot be done.	<ul style="list-style-type: none"> • Rice may cook later by about 10 minutes. if the room temperature / water temperature is low, and the amount of water is large. • Has the inner pot been put properly in the cooker, when setting the pre-programmed operation? • Did you forget to set the cooker for pre-programmed operation, or forget to press "COOK" key or something like that ?
Operation • Indications	It is hard to close the lid The lid cannot be closed	<ul style="list-style-type: none"> • Is the inner lid attached properly? In order to prevent forgetting to attach the inner lid, the outer lid cannot be closed completely without the inner lid attached. • Are there any foreign substances stuck in the gap of hook button, etc.?
	Key operation cannot be done	<ul style="list-style-type: none"> • Is the plug inserted ? Is the inner lid attached? • While selecting "Food Preparation" course, such as<Cake>, the "TIMER" key is not accepted despite pressing it.
	The "COOK" lamp goes out The operation stops half way	<ul style="list-style-type: none"> • If the "Cancel" key is pressed by mistake, or if a power failure lasts for a long period, the power will be cut off.
	The remaining cook time indicated is not the same as that of real cooking.	<ul style="list-style-type: none"> • It is possible that the remaining cook time indicated may not be the same as that of real cooking. It is not because the cooker is out of order. The actual time results may vary depending on ingredients, room temperature, etc.
	The indicator of time spent in "Keep Warm" mode blinks	<ul style="list-style-type: none"> • It indicates that the rice has been kept warm for a long period of time, so please stop it.

Trouble Cases ▶ **Causes / Points of investigation**

Food Preparing	It takes a long time to prepare food. The setup time does not decrease.	<ul style="list-style-type: none"> The setup time starts from the "ready-to-cook" temperature. However, it needs some time for heating until the temperature gets ready for cooking. Therefore, real cooking times will be longer than setup times.
	The food is not well made.	<ul style="list-style-type: none"> Finished condition of cooked food may vary depending on ingredients and measuring methods, etc. Please check and confirm the cooking procedures and cooking times. The following factors may lead to cooking failure, steam leakage, or cause the lid not to close properly. Foreign substances stick to the temperature sensor. The inner pot is deformed. Cooked food is left in the pot. There was a power failure. The cooker connection plug was not inserted in the socket.
Others	It sounds when cooking.	<ul style="list-style-type: none"> [Tik] heat adjustment sound, [Chu] steaming sound. (It is not because of malfunctioning). [JuJu] sound of water droplets splattering and burning at the outer surface of inner pot Please wipe off water droplets at the outer surface of inner pot before putting it into the cooker.
	There is plastic smell.	<ul style="list-style-type: none"> At the beginning of use, there may be some unpleasant smell, but it will disappear little by little while using → if feeling worry, please clean it by boiling .
	There are scratches, dirt on the outer surface of inner pot.	<ul style="list-style-type: none"> After using, coated inner surface may get scratched or get dirty, but there will be no effect on cooking or warming quality.
	The circuit breaker is off , when cooking food.	<ul style="list-style-type: none"> If using the cooker with other electric appliances in the same time, power consumption may be overrated, causing the circuit breaker to cut off power. Please use an isolated outlet.

In case of a power failure

Please do in the same way as when the cooker is halfway unplugged, When the cooker connection plug falls out, or when the breaker cuts off power.

During pre-programmed cooking	<ul style="list-style-type: none"> After restoring from a power failure, the cooker will restore to the original state.
During rice cooking	
During keeping warm /	
During steam boiling	

※If the power failure lasts for a long time, the rice may be not well cooked.

ERROR INDICATION

Anomaly self-checking

Display the cause of the abnormality network for repair or installation.

Please contact your local dealer or service

Indicat or state	Abnormal display	Possible Reason	Solutions
Light on	1 88	Main thermistor (bottom sensor) open circuit	Pull out and re-connect the power cord, the display still shows same message, please send the cooker to your local after-sales service centre for maintenance.
Light on	2 88	Main thermistor (bottom sensor) short circuit	
Light on	5 85	Top lid sensor (handle thermistor) open circuit	
Light on	6 86	Top lid sensor (handle thermistor) short circuit	
Light on	8 80	Abnormal temperature system error	
Light on	8 88	Communication error	
Flash	8 88	Communication error	

Specifications

Model Name	Power Supply	Power Consumption (COOK)	Body Dimension	Body Weight	Frequency
RC-18DR1NMY	220-240V~	780-928W	L393*W287*H254(mm)	4.4kg	50/60Hz
RC-10DH1NMY	220-240V~	605-720W	L368*W271*H212(mm)	3.2kg	50/60Hz
RC-18DH1NMY		760-904W	L393*W287*H254(mm)	3.9kg	50/60Hz